

Please note that these are general purpose instructions, supplied in good faith and may not be suitable for all jobs. In particular, the screws used to fix brackets must be adequate and suitable for the wall surface. The screws supplied may not be suitable for all purposes.

1. For Finials with Screw Fitting

Use a 9mm drill to make the required hole in the end of the pole to a depth of approx 40mm and fit the supplied blue rawlplug into it. The small hole which you may observe at each end of the pole is produced by the manufacturing process and is **not** intended to accommodate the rawlplug.

Attach the finial by gently screwing it into the plug until a firm fit is obtained.

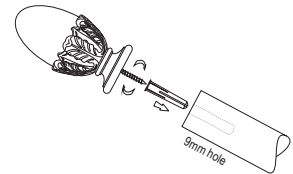

2. For Finials with Locking Collars

Slacken the small grub screw on the metal collar of the finial using the hexagon head Allen Key provided.

Slide the finial onto the pole and re-tighten the grub screw again until a firm fit is obtained.

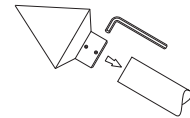

BASIC METHOD OF FIXING FOR MOST BRACKETS AND TIEBACKS

1. Base-plate fixings

Attach the fixing plate from the base of the bracket or tieback to the wall in the desired position. For best support you should ensure that two screws are used in the top half of the plate.

Screw the bracket or tieback onto each base plate until it is firmly, but not overtight, against the wall.

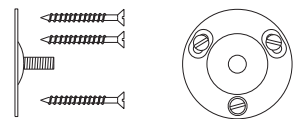

2. Keyhole fixings

Mark the screw positions carefully on the wall, noting the exact position of the keyhole plate slot within the bracket. Note that the bracket will 'drop' by roughly 10mm as the plates engage onto the screw heads.

After drilling and plugging the wall, fit the screws so that the head is left projecting by a few millimetres and then offer up the bracket so that the bottom (wider part) of the keyhole just passes over the head of the screw.

Gently lower the bracket into position to fully engage the screw head into the narrow end (top) of the keyhole. Check the fixing for tightness and adjust the screw in or out until a firm fit is obtained.

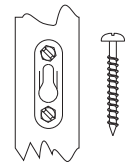

BRACKET STYLES

B10 Standard Metal Bracket

Fixed using plugs and screws through the 3 plain holes in the base, ensuring that the small hole in the bracket stem (H) is positioned so that its wider, countersunk end is **downwards**.

Position the pole onto the top of the bracket stem and use small wood screw passed up through the stem hole (H) to secure it. We recommend drilling a small pilot hole in the pole first.

If required, insert small mushroom covers into the heads of the base fixing screws to finish.

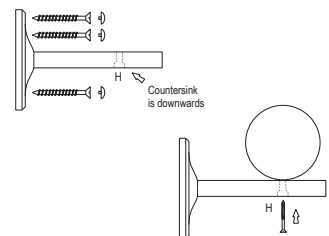

B01 (End & Centre styles)

Fix using the keyhole plates on the rear (see basic instructions).

To fit the pole, rest it carefully onto the small metal pin (P) which protrudes from the top of the bracket and carefully mark where the pin touches the pole. Drill a 6mm diameter hole into the pole, to a depth of 25mm, at each bracket position. Finally, replace the pole onto the brackets ensuring that the pins slide properly into the drilled holes.

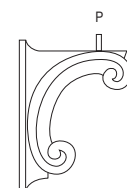

B19, B34 Wooden Cup Brackets

These brackets are attached using a threaded base plate (see basic instructions).

Place the pole into the bracket cups in the correct position and secure through the hole in the bottom of the bracket (H) using the small screw provided.

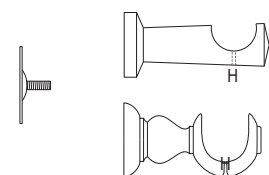

B25 Brass Bracket (End & Centre styles)

Carefully mark the position for the brackets and drill and plug the wall. Fix with screws through the countersunk holes. If required, insert small mushroom covers into the heads of the fixing screws to finish neatly.

Place the pole into the cup of the bracket and gently tighten the decoration to secure.

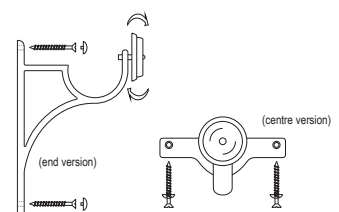

B24 Ash/Steel Bracket

Unscrew the small wooden decoration (D) from the stem and slide the base cover (C) off to leave the metal bracket base exposed. Fix using 3 plain holes in the base (see basic instructions).

Important: Ensure that the small hole in the bracket stem (H) is positioned so that its wider, countersunk end is downwards.

Slide the base cover back on, securing it gently with the grub screw positioned at the top.

Place the pole onto the top of the bracket stem and use a small wood screw passed up through the stem hole (H) to secure it. For hardwood poles, particularly Ash, it is important to premark and drill a small pilot hole in the pole first.

Screw the decoration back onto the end of the stem again to finish.

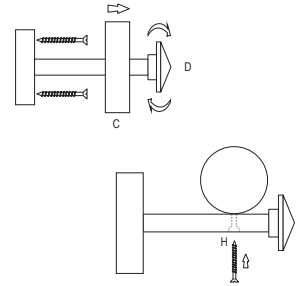

B35 Flat Wooden Bracket

Carefully mark the position for the brackets and drill and plug the wall. Fix with screws through the countersunk holes. Use small screw passed up through the underside (H) to secure. We recommend drilling a small pilot hole in the pole first.

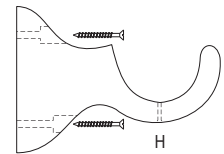

B08, B09, B20, B21, B22 Decorative Brackets

Fix using the keyhole plates on the rear (see basic instructions).

The pole is supported by passing it through the large loop in the top part of the bracket and securing it firmly by means of a bolt or screw which grips the rear of the pole.

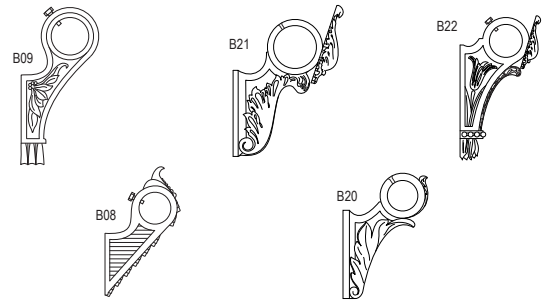

B27 Steel Bracket

Loosen the grub screw (G) using the Allen key provided. Remove the stem section and cover plate from the metal base of the bracket.

Attach the base plate (B) to the wall in the desired position using screws and plugs provided. Replace the cover disc (C) over the base.

Slide the bracket sleeves/stems carefully onto the pole, being careful not to scratch it.

Making sure that the grub screw (G) in the stem is not obstructing the socket, slide the stem carefully back onto the base. Take care that the stem is fully 'home' onto the base spigot. Tighten all grub screws.

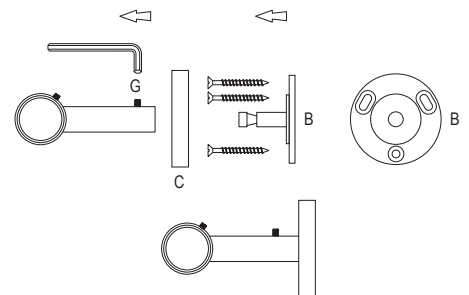

B29 Steel Recess Socket

Unscrew the base mount from the cover sleeve of the socket. Position and fix the base plate to the wall using the single screw and rawplug provided.

Making sure that the grub screw (G) is not causing any obstruction, slide the cover sleeve onto the pole, being careful not to scratch it.

Fix the pole onto the base plate by screwing the cover sleeve back onto the base and tighten the grub screw firmly using the Allen key provided.

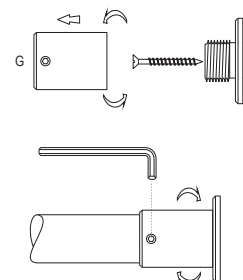

B26 Wooden Recess Socket

Unscrew the fixing plate from the base of the socket by turning anticlockwise and attach to the wall in the same manner as described for the bracket.

Screw the wooden socket back onto the base plate until it is firmly against the wall. Slot the pole into the recess socket.

Where a recess socket is being used on **BOTH** ends of a pole please note that the pole will need to be **slightly** shorter than the wall-to-wall distance to allow for the space occupied by the two socket bases.

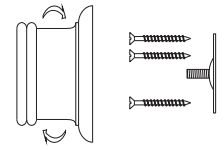

We recommend the easiest method for achieving the correct fit in this situation is as follows:

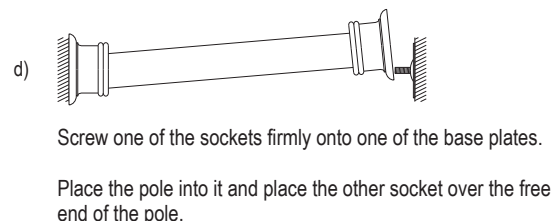
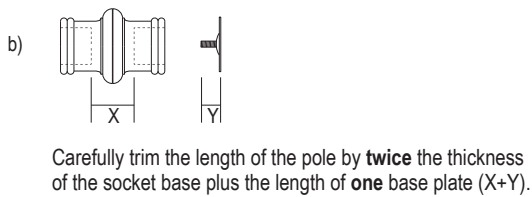
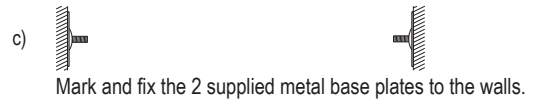
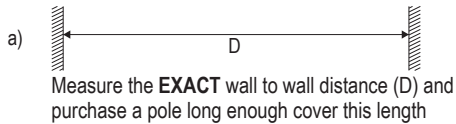

Do NOT remove too much!

Lift the pole into position.

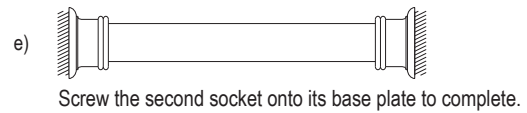
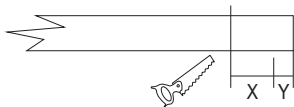

Slight left to right movement of the pole is normal, but if desired this can be minimised by securing with a small screw.

TIEBACK STYLES

T16 Ash/Steel Tieback

T16 tiebacks are similar to the B24 brackets. Screw the base onto the wall in the same way and replace the wooden cover after fitting.

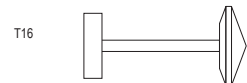

T27, T30 Steel Tiebacks

Attach base plate to the wall and fit in exactly the same way as the B27 steel brackets.

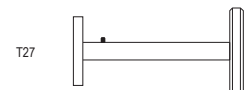

T21, T28 Wooden Tieback

These items are fitted using a threaded base plate in the same way as the B19 wooden brackets.

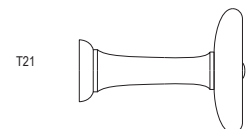

T01, T05, T12, T13, T14, T15 & other Tiebacks with wooden stems

Fitted by means of a simple screw projecting from the base. Please ensure that the wall is properly drilled and plugged, using the supplied blue rawlplug, before attaching the tieback.

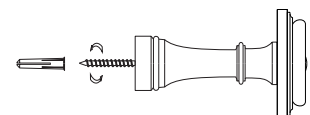

1. Measuring from the corner, above the window, mark the positions for the bracket bases as shown below.

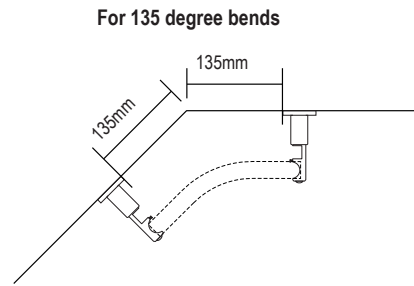
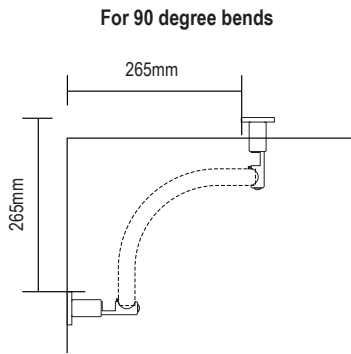

2. Fit the base plate of the bracket to the wall, in the position marked, and then place the cover plate over the base and screw the sleeve onto the base to retain it.

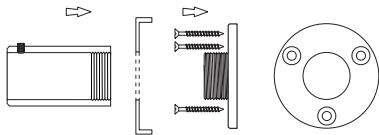

3. The pole is placed into the small semi-circular recess in the bracket and secured with the small screw at the back. A small amount of adjustment is present in the bracket, as below.

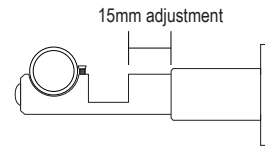

4. The joining plug that fixes the sections together should ideally be positioned over the centre of each bracket.

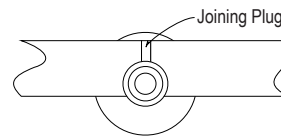

5. When used correctly this bracket is extremely strong but when fitting you should always ensure that the warning line which is engraved around the barrel is **NOT** showing.

Push the barrel in until this line disappears, then lock it **firmly** into position with the small grub screw on the top of the bracket sleeve.

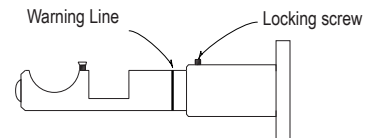

6. Fix the remaining brackets around the window in the desired positions, with a bracket at each pole joint position. On sections without joints you should also ensure that the brackets are no further than 2 metres apart.

7. Each bracket has a small screw to fix the pole in position. It is only necessary to use these screws for the brackets at the ends and the centre of the window.

For all brackets where you require the 'C' rings to **pass** the bracket (ie. corners or long straight sections) these screws should be **removed**.

